

12FT Pro Series Tilt Bed Equipment

G.V.W.R.	12,000#	AXLES	Two 6,000#, 4" Drop EZ Lube w/Electric Brakes
G.A.W.R. (Ea. Axle)	6,000#	SUSPENSION	Multi-Leaf Slipper Spring with Equalizer
COUPLER	Adjustable Forged 2-5/16"	TIRE	ST235/80 D-16 Load Range E
SAFETY CHAINS	1/4" Grd. 70 w/Safety Latch Hook (2 each)	WHEEL	16 x 6 White Spoke 8 Bolt
JACK	7K Drop Leg Jack (Bolted On)	FLOOR	2" Pine
TONGUE	5" Channel Fold Back	LIGHTS	D.O.T. Stop, Tail, Turn & Clearance
TOP RAIL	None	ELEC. PLUG	7-Way RV
FRAME	6" Channel	FINISH (Prep)	Steel is Cleaned to Ensure a Professional Smooth Finish.
CROSSMEMBERS	3" Channel, 3" Sq. Tube	FINISH	Superior Quality Finish is Applied for a Highly Decorative and Protective Finish.
UPRIGHTS	None		
FENDERS	9" x 72" Double Square Broke Diamond Plate w/Back (Bolted On)		

Standard Features

- Adjustable Forged Coupler
- Fold Back Tongue w/Raised Coupler
- Safety Chains Attached w/Cold Rolled Eyelets
- Lower Jack Support Plate
- Unique Two Piece Main Frame
- 102" Wide Overall, 83" Width Between Fenders
- Tilt Platform is 75" Wide
- Hydraulic Dampening System
- Stake Pockets & Rubrail
- Floor Secured w/Torx Screws
- Cambered 4" Drop EZ Lube Axles w/Electric Brake on Each
- Complete Break-A-Way System w/Charger
- Spare Tire Mount
- 1/4" Diamond Plate Knife Edge
- Rubber Mounted Sealed Lighting

Dimensions				
Length	A	B	C	D
16'	202-1/2"	101"	101-1/2"	13°
18'	225-1/2"	113"	112-1/2"	12°
20'	249-1/2"	128"	121-1/2"	11°

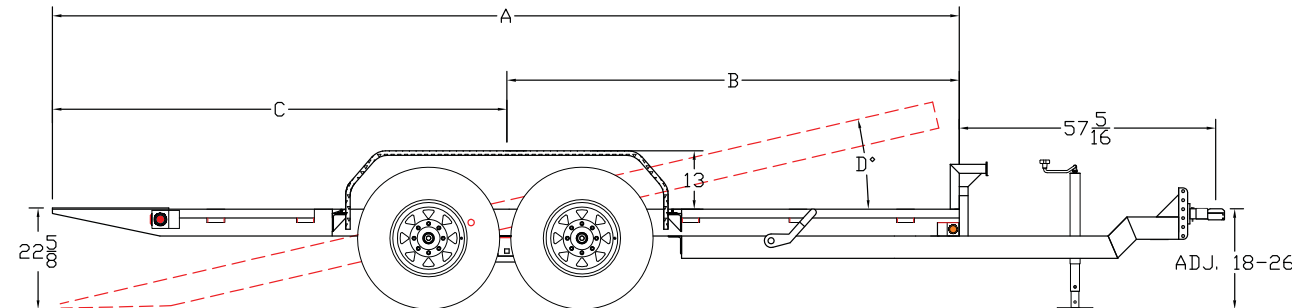

MODEL#	WEIGHT	DESCRIPTION
12FT-16	2,875#	83" x 16' Tilt Trailer
12FT-18	2,900#	83" x 18' Tilt Trailer
12FT-20	3,120#	83" x 20' Tilt Trailer

OPTIONS

Adjustable Pintle in Channel	Spare Tire (ST235/80 D-16 LR-E)
12K Drop Leg Jack - Top Wind	Tire Upgrade (ST235/80 R-16 LR-E)
12K Drop Leg Jack - Side Wind Against Bed	Spare Tire Upgrade (ST235/80 R-16 LR-E)
Hydraulic Surge Brakes 2 Axles	LED Lighting