

70SR Tandem Axle Single Ram Dump

G.V.W.R.	7,000#	AXLES	Two 3,500# EZ Lube w/Elec. Brakes
G.A.W.R. (Ea. Axle)	3,500#	SUSPENSION	Multi-Leaf Spring w/Equalizer
COUPLER	2-5/16" Stamped A-Frame	TIRE	ST205/75-15 Load Range C
SAFETY CHAINS	1/4" Grd. 70 w/Safety Latch Hook (2 each)	WHEEL	15 x 5 White Spoke 5 Bolt
JACKS	2K Top Wind (Bolted On)	FLOOR	16 Gauge Smooth Steel
TONGUE	5" Channel	LIGHTS	LED D.O.T. Stop, Tail, Turn & Clearance
FRAME	5" Channel	ELEC. PLUG	7-Way RV
CROSSMEMBERS	6" Channel	FINISH (Prep)	Steel is Cleaned to Ensure a Professional Smooth Finish.
BED CROSSMEMBERS	2" x 2" Square Tubing	FINISH	Superior Quality Finish is Applied for a Highly Decorative and Protective Finish.
BED SIDE RAILS	3" x 2" Tubing		
FENDERS	9" x 72" DSB Diamond Plate		

Standard Features

- Safety Chains Attached w/Cold Rolled Eyelets
- Lockable Pump & Battery Box Mounted in Front of Bed
- 20", 16 Ga. Sides w/Formed Channel Supports
- J-Hooks for Tie Down
- Tarp Brackets
- Single Cylinder Lift
- 45 Degree Dump Angle
- Cambered EZ Lube Axles w/Electric Brake on Each
- Complete Break-A-Way System w/Charge Line
- Grommet Mount Sealed LED Lighting
- 1 Piece 2 Way Style Rear Gate

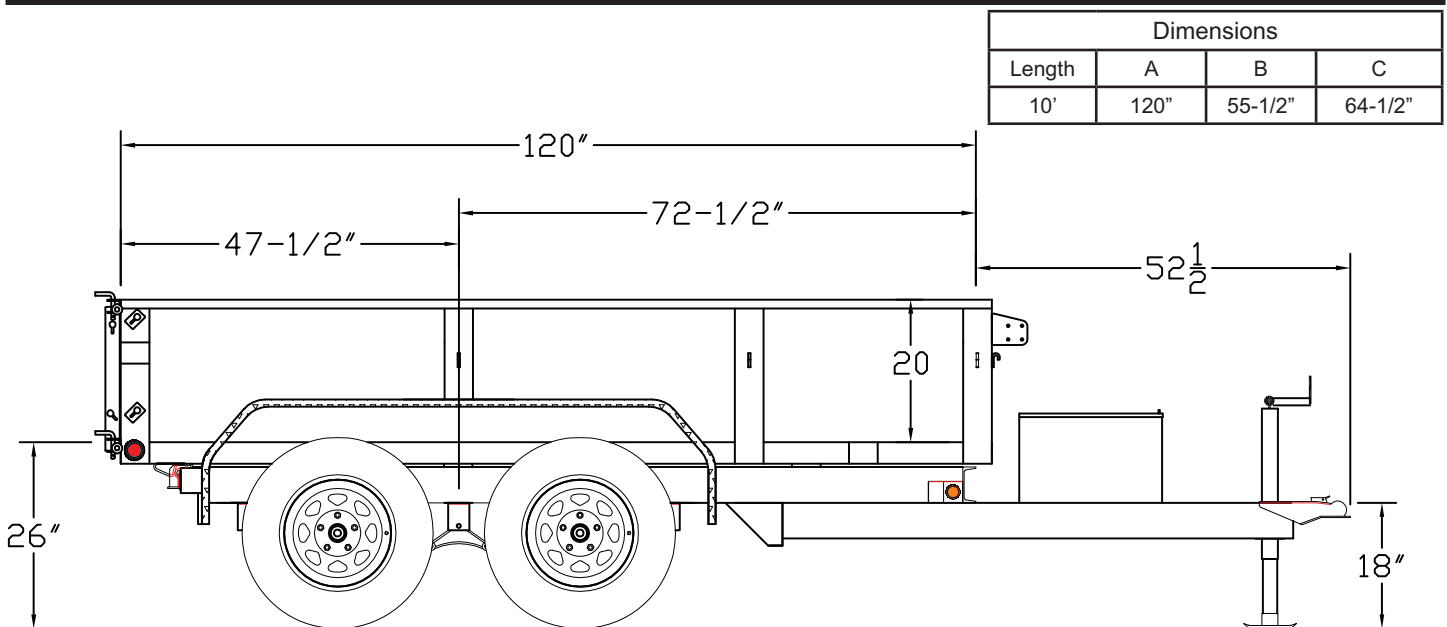

MODEL#	DESCRIPTION
70SR-10-5W	60" x 10' Tandem Axle Single Ram Dump
70SR-10	72" x 10' Tandem Axle Single Ram Dump

TRAILER WEIGHTS & CAPACITIES

LENGTH	EMPTY WEIGHT	PAYLOAD	BOX CAPACITY
10'-5W	1,730#	5,120#	3.0 Cubic Yards
10'	2,000#	5,000#	3.75 Cubic Yards

OPTIONS

Spare Tire (ST205/75-15 LR-C)	5 Watt Solar Charger
Wireless Remote	110V Charger
2 Watt Solar Charger	Crank Style Roll Tarp