

60SP Tandem Axle Pipe Special

G.V.W.R.	6,000#	AXLES	Two 3,500# EZ Lube w/1 Elec. Brake
G.A.W.R. (Ea. Axle)	3,500#	SUSPENSION	Multi-Leaf Spring w/Equalizer
COUPLER	2" A-Frame	TIRE	ST205/75-15 Load Range C
SAFETY CHAINS	1/4" Grd. 70 w/Safety Latch Hook (2 each)	WHEEL	15 x 5 White Spoke 5 Bolt
JACK	2K Top Wind (Bolted On)	FLOOR	2" Pine
TONGUE	4" Channel A-Frame	LIGHTS	D.O.T. Stop, Tail, Turn & Clearance
TOP RAIL	2-3/8" Pipe Square Back	ELEC. PLUG	7-Way RV
FRAME	4" x 3" x 1/4" Angle	FINISH (Prep)	Steel is Cleaned to Ensure a Professional Smooth Finish.
CROSSMEMBERS	3" x 2" x 3/16" Angle	FINISH	Superior Quality Finish is Applied for a Highly Decorative and Protective Finish.
UPRIGHTS	16" Tall 3" x 2" x 3/16" Angle		
FENDERS	9" x 72" Rolled Formed w/Back		

Standard Features

- Safety Chains Attached w/Cold Rolled Eyelets
- Sand Foot on Jack
- Lower Jack Support Plate
- 2-3/8" Top Rail Capped w/Self Sealing Plugs
- Floor Secured w/Torx Screws
- 4 Tie Down Loops
- Cambered EZ Lube Axles w/1 Electric Brake
- Complete Break-A-Way System w/Charger
- Grommet Mount Sealed Lighting
- Black Only

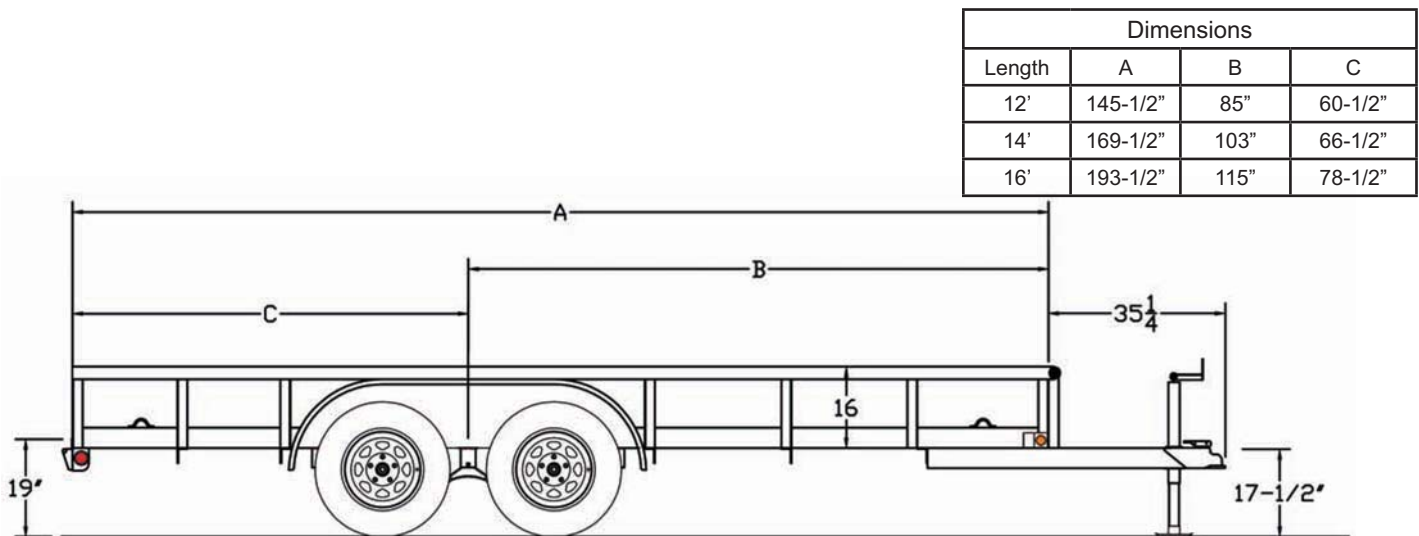

MODEL#	WEIGHT	DESCRIPTION
60SP-12	1,302#	77" x 12' Tandem Axle Trailer
60SP-14	1,410#	77" x 14' Tandem Axle Trailer
60SP-16	1,610#	77" x 16' Tandem Axle Trailer

OPTIONS

Electric Brakes on 2nd Axle	4' Slide In Ramps
Spare Tire Mount	4' Rampgate (6.5 W)
Spare Tire (ST205/75-15 LR-C)	Gas Spring Assist Option - Rampgate
LED Lighting	

STANDARD MODEL - NO OTHER OPTIONS AVAILABLE - BLACK ONLY