

# 45SS Tandem Axle Utility

<b>G.V.W.R.</b>	4,490#	<b>AXLES</b>	Two 3,500# EZ Lube Axles w/1 Elec Brake
<b>G.A.W.R. (Ea. Axle)</b>	3,500#	<b>SUSPENSION</b>	Multi-Leaf Spring
<b>COUPLER</b>	2" A-Frame	<b>TIRE</b>	ST205/75-15 Load Range C
<b>SAFETY CHAINS</b>	1/4" Grd. 30 w/Safety Latch Hook (2 each)	<b>WHEEL</b>	15 x 5 White Spoke 5 Bolt
<b>JACK</b>	2K Top Wind (Bolted On)	<b>FLOOR</b>	2" Pine
<b>TONGUE</b>	4" Channel	<b>LIGHTS</b>	D.O.T. Stop, Tail, Turn & Clearance
<b>TOP RAIL</b>	2-3/8" Pipe Top Rail	<b>ELEC. PLUG</b>	7-Way RV
<b>FRAME</b>	3" x 2" x 3/16" Angle	<b>FINISH (Prep)</b>	Steel is Cleaned to Ensure a Professional Smooth Finish.
<b>CROSSMEMBERS</b>	3" x 2" x 3/16" Angle	<b>FINISH</b>	Superior Quality Finish is Applied for a Highly Decorative and Protective Finish.
<b>UPRIGHTS</b>	15" Tall, 2" x 2" x 1/8" Angle		
<b>FENDERS</b>	9" x 72" Rolled Formed w/Back		

## Standard Features

- Safety Chains Attached w/Cold Rolled Eyelets
- Lower Jack Support Plate
- Complete Break-A-Way System w/Charger
- Sand Foot on Jack
- Floor Secured w/Torx Screws
- Grommet Mount Sealed Lighting
- Cambered EZ Lube Axles w/1 Electric Brake

Dimensions			
Length	A	B	C
16'	193-1/2"	115"	78-1/2"

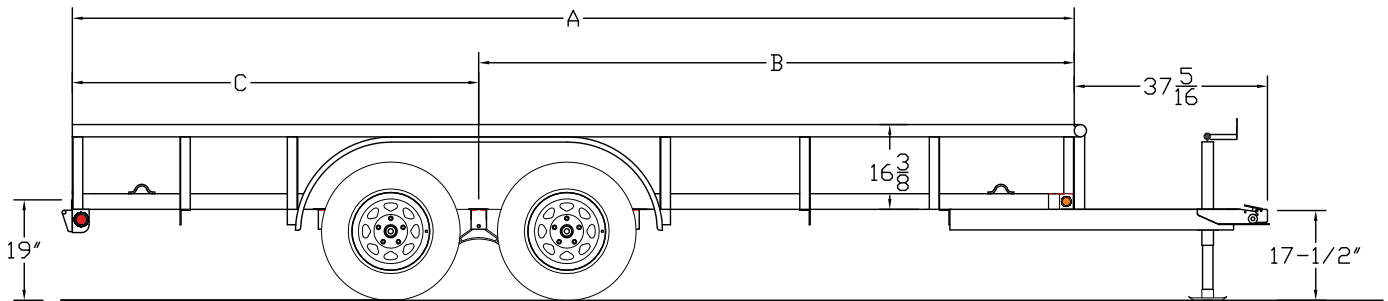

MODEL#	WEIGHT	DESCRIPTION
45SS-16	1,400#	77" x 16' Tandem Axle Pipe Trailer

### OPTIONS

No Brakes	Spare Tire (ST205/75-15 LR-C)
Electric Brakes on 2 Axles	LED Lighting
Spare Tire Mount (Side)	4' Rampgate (6.5 W)

STANDARD MODEL - NO OTHER OPTIONS AVAILABLE