

3XGN Super Duty Tandem Dual Axle Gooseneck

G.V.W.R.	30,000#	AXLES	Two HD 15,000# Dual Wheel Electric Brakes (Oil Bath)
G.A.W.R. (Ea. Axle)	15,000#	SUSPENSION	44K Adjustable
COUPLER	30K, 2-5/16" Ball Crank Type Adjustable	TIRE	215/75R 17.5 Load Range H
SAFETY CHAINS	1/2" Grd. 80 w/Safety Latch Hook (2 each)	WHEEL	17.5 HC x 6.75 8x275MM BC Hub Pilot
JACK	Dual Two Speed Landing Gear (Bolted On)	FLOOR	2" Pine
NECK	12" I-Beam	LIGHTS	LED D.O.T. Stop, Tail, Turn & Clearance w/Ctr Turns
TOP RAIL	None	ELEC. PLUG	7-Way RV
FRAME	12 x 22# Up To 30', 14 x 22# on 30' +	FINISH (Prep)	Steel is Cleaned to Ensure a Professional Smooth Finish.
CROSSMEMBERS	6" Jr. I-Beam, 16" Centers	FINISH	Superior Quality Finish is Applied for a Highly Decorative and Protective Finish.
SIDE RAILS	8" Channel w/Rub Rail, Stake Pockets on 24" Centers, and Chain Spools		

Standard Features

- Safety Chains Attchd w/Cold Rolled Eyelets
- Modular Sealed Wiring Harness
- 102" Overall Width
- Low Profile Bed, Pierced Frame
- 28' (Flat Deck) and Longer Include Torque Tube
- Lockable Toolbox Between GN Uprights
- Safety Reflective Marker Tape
- Rubber Mounted Sealed LED Lighting
- Heavy Duty Oil Bath Axles w/Electric Brake on Each
- 1-1/4" Pipe Chain Spools Between Stake Pockets
- Complete Break-A-Way System w/Battery & Charger
- Spare Tire Mount
- 2 Side Bed Steps
- 5' Dove Tail w/Double Hinged Spring Assist Fold Over Ramps

Dimensions w/Straight Deck				w/Dovetail	
Length	A	B	C	B	C
20'	240"	160"	80"	186"	54"
24'	288"	192"	96"	232"	56"
26'	312"	208"	104"	248"	64"
28'	336"	224"	112"	264"	72"
30'	360"	240"	120"	280"	80"

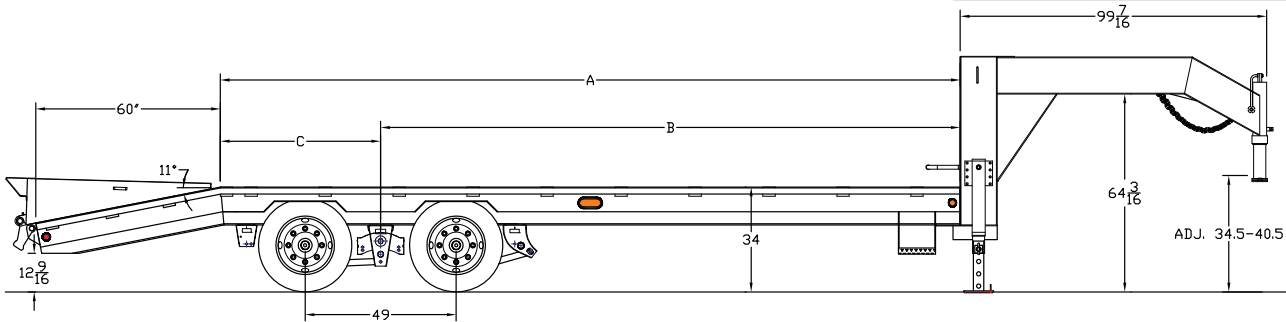

MODEL#	WEIGHT	DESCRIPTION
*3XGN-20+5	6,230#	102" x 20' + 5' Tandem Dual 30,000# Gooseneck
*3XGN-24+5	7,190#	102" x 24' + 5' Tandem Dual 30,000# Gooseneck
*3XGN-26+5	7,670#	102" x 26' + 5' Tandem Dual 30,000# Gooseneck
*3XGN-28+5	8,150#	102" x 28' + 5' Tandem Dual 30,000# Gooseneck
*3XGN-30+5	8,630#	102" x 30' + 5' Tandem Dual 30,000# Gooseneck

OPTIONS

Air Brake w/ABS on Front, Spring Break Chambers & Auto Slacks	Low Profile Tool Box 12" x 18" x 36" Side Mount
Electric Over Hydraulic Brakes (Drum)	Deck on the Neck (6')
Spare Tire (215/75R 17.5 LR-H)	No Dovetail Option (Straight Deck)

* Trailer is subject to Federal Excise Tax