

21GX Triple Axle Low Profile Extra Wide Dump

| | | | |
|----------------------------|---|----------------------|---|
| G.V.W.R. | 21,000# | AXLES | Three 7,000# EZ Lube w/Elec. Brake |
| G.A.W.R. (Ea. Axle) | 7,000# | SUSPENSION | Multi-Leaf Slipper Spring w/Equalizer |
| COUPLER | 2-5/16" Adjustable Pipe | TIRE | ST235/80 R-16 Load Range E |
| SAFETY CHAINS | 3/8" Grd. 70 w/Safety Latch Hook (2 each) | WHEEL | 16 x 6 HD White Modular 8 Bolt |
| JACKS | Dual 12K SW Drop Legs | FLOOR | 10 Gauge Smooth Steel |
| NECK | 8" Channel | LIGHTS | LED D.O.T. Stop, Tail, Turn & Clearance |
| FRAME | 8" x 3" Rect Tube | ELEC. PLUG | 7-Way RV |
| CROSSMEMBERS | 6" Channel, 3" x 3" Tubing | FINISH (Prep) | Steel is Cleaned to Ensure a Professional Smooth Finish. |
| BED CROSSMEMBERS | 3" Channel | FINISH | Superior Quality Finish is Applied for a Highly Decorative and Protective Finish. |
| BED LONG SILS | 5" Channel | | |
| BED SIDE RAILS | 6-1/2" Formed Angle | | |
| FENDERS | Double Square Broke Diamond Plate | | |

Standard Features

- Safety Chains Attached w/Cold Rolled Eyelets
- Lockable Pump & Battery Box Mounted in Front of Bed
- Modular Sealed Wiring Harness
- 24", 12 Ga. Sides w/Formed Channel Supports
- 10 Ga. Floor
- J-Hooks for Tie Down
- Stake Pockets
- Fully Formed Shroud for Tarp
- 4-5/8" D-Rings Inside Bed
- Fully Self Contained Electric Hydraulic Scissor Lift
- 45 Degree Dump Angle
- Cambered EZ Lube Axles w/Electric Brake on Each
- Complete Break-A-Way System w/Charge Line
- Spare Mount
- Grommet Mount Sealed LED Lighting
- Combo Gate

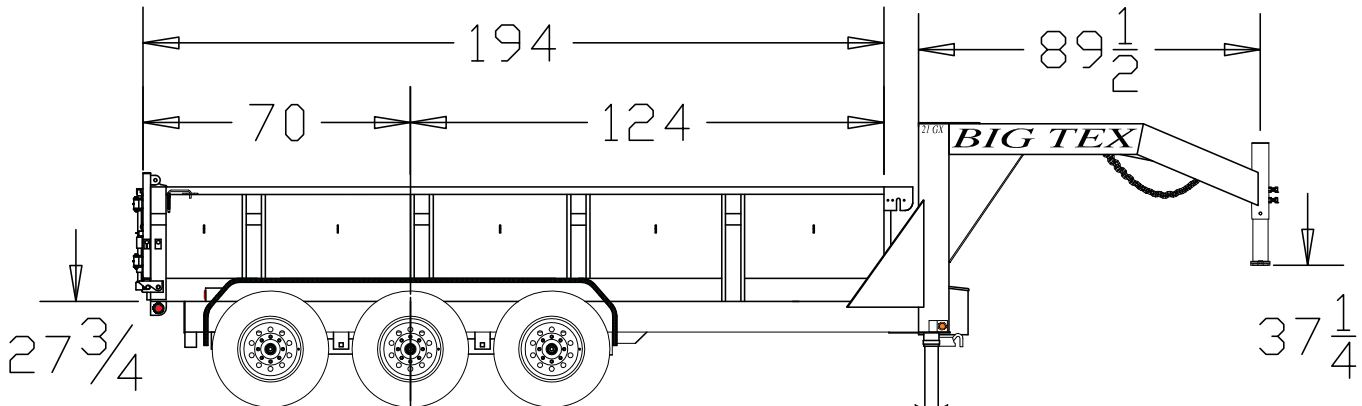

| MODEL# | DESCRIPTION |
|---------|--|
| 21GX-16 | 83" x 16' Low Profile Tandem Axle Gooseneck Dump |

TRAILER WEIGHTS & CAPACITIES

| LENGTH | EMPTY WEIGHT | PAYLOAD | BOX CAPACITY |
|---------|--------------|---------|-----------------|
| 21GX-16 | 6,160# | 14,800# | 8.3 Cubic Yards |

OPTIONS

| | |
|------------------------------------|-----------------------|
| Spare Tire (ST235/80 R-16 LR-E) | Wireless Remote |
| Tire Upgrade (ST235/16 LR-G) | 2 Watt Solar Charger |
| Spare Tire Upgrade (ST235/16 LR-G) | 5 Watt Solar Charger |
| Expanded Metal Side Extensions | 110V Charger |
| 7' Slide In Ramps | Crank Style Roll Tarp |