

14LX Tandem Axle Low Profile Extra Wide Dump

G.V.W.R.	14,000#	AXLES	Two 7,000# EZ Lube w/Elec. Brake
G.A.W.R. (Ea. Axle)	7,000#	SUSPENSION	Multi-Leaf Slipper Spring w/Equalizer
COUPLER	2-5/16" Adjustable Forged	TIRE	ST235/80 R-16 Load Range E
SAFETY CHAINS	3/8" Grd. 70 w/Safety Latch Hook (2 each)	WHEEL	16 x 6 HD White Modular 8 Bolt
JACKS	7K TW Drop Leg	FLOOR	10 Gauge Smooth Steel
TONGUE	6" Channel Fold Back	LIGHTS	LED D.O.T. Stop, Tail, Turn & Clearance
FRAME	6" x 3" Tube on 14' / 8" x 3" Tube on 16'	ELEC. PLUG	7-Way RV
CROSSMEMBERS	6" Channel	FINISH (Prep)	Steel is Cleaned to Ensure a Professional Smooth Finish.
BED CROSSMEMBERS	3" Channel	FINISH	Superior Quality Finish is Applied for a Highly Decorative and Protective Finish.
BED LONG SILS	3" Channel		
BED SIDE RAILS	6-1/2" Formed Angle		
FENDERS	Double Square Broke Diamond Plate		

Standard Features

- Safety Chains Attached w/Cold Rolled Eyelets
- Lockable Pump & Battery Box Mounted in Front of Bed
- Modular Sealed Wiring Harness
- 24", 12 Ga. Sides w/Formed Channel Supports
- 10 Ga. Floor
- J-Hooks for Tie Down
- Stake Pockets
- Fully Formed Shroud for Tarp
- 4-5/8" D-Rings Inside Bed
- Fully Self Contained Electric Hydraulic Scissor Lift
- 45 Degree Dump Angle
- Cambered EZ Lube Axles w/Electric Brake on Each
- Complete Break-A-Way System w/Charge Line
- Grommet Mount Sealed LED Lighting
- Combo Gate

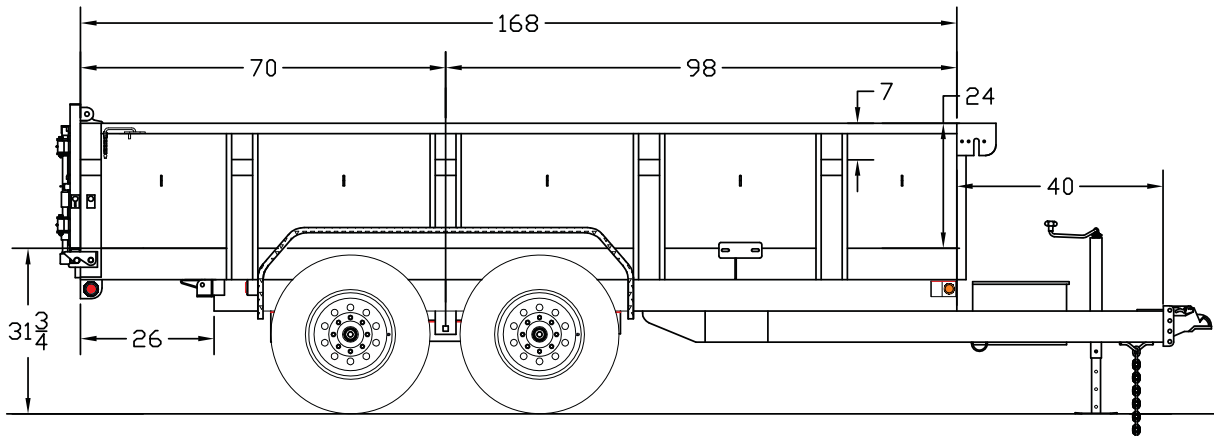

MODEL#	DESCRIPTION
14LX-14	83" x 14' Low Profile Tandem Axle Bumper Pull Dump
14LX-16	83" x 16' Low Profile Tandem Axle Bumper Pull Dump

TRAILER WEIGHTS & CAPACITIES

LENGTH	EMPTY WEIGHT	PAYLOAD	BOX CAPACITY
14LX-14'	4,140#	9,860#	7.2 Cubic Yards
14LX-16'	4,500#	9,500#	8.3 Cubic Yards

OPTIONS

Spare Tire (ST235/80 R-16 LR-E)	Wireless Remote
Tire Upgrade (ST235/16 LR-G)	2 Watt Solar Charger
Spare Tire Upgrade (ST235/16 LR-G)	5 Watt Solar Charger
Expanded Metal Side Extensions - 14'	110V Charger
Expanded Metal Side Extensions - 16'	Crank Style Roll Tarp
7' Slide In Ramps	