

14OD/14OD-GN Tandem Over The Axle Dump

G.V.W.R.	14,000#	AXLES	Two 7,000# EZ Lube w/Elec. Brake
G.A.W.R. (Ea. Axle)	7,000#	SUSPENSION	Multi-Leaf Slipper Spring w/Equalizer
COUPLER	2-5/16" Adjustable Forged - OD 2-5/16" Adjustable Pipe - OD GN	TIRE	ST235/80 R-16 Load Range E
SAFETY CHAINS	3/8" Grd. 70 w/Safety Latch Hook (2 each)	WHEEL	16 x 6 HD White Modular 8 Bolt
JACKS	OD-12K TWDrop Leg OD GN-Dual 12K SW Drop Legs	FLOOR	10 Gauge Smooth Steel
TONGUE	12" I-Beam	LIGHTS	LED D.O.T. Stop, Tail, Turn & Clearance
FRAME	12" I-Beam	ELEC. PLUG	7-Way RV
CROSSMEMBERS	4" I-Beam and 3" x 3" Tube	FINISH (Prep)	Steel is Cleaned to Ensure a Professional Smooth Finish.
BED CROSSMEMBERS	3" Channel	FINISH	Superior Quality Finish is Applied for a Highly Decorative and Protective Finish.
BED LONG SILS	5" Channel		
BED SIDE RAILS	4" x 3" Angle		

Standard Features

- Safety Chains Attached w/Cold Rolled Eyelets
- Lockable Pump & Battery Box Mounted in Front of Bed
- Modular Sealed Wiring Harness
- 18", 10 Ga. Fold Down Sides
- 10 Ga. Floor
- Fully Formed Shroud for Tarp
- 4-5/8" D-Rings Inside Bed
- Fully Self Contained Electric Hydraulic Scissor Lift
- 45 Degree Dump Angle
- Cambered EZ Lube Axles w/Electric Brake on Each
- Complete Break-A-Way System w/Charge Line
- Grommet Mount Sealed LED Lighting
- 7' Slide In Ramps
- Combo Gate

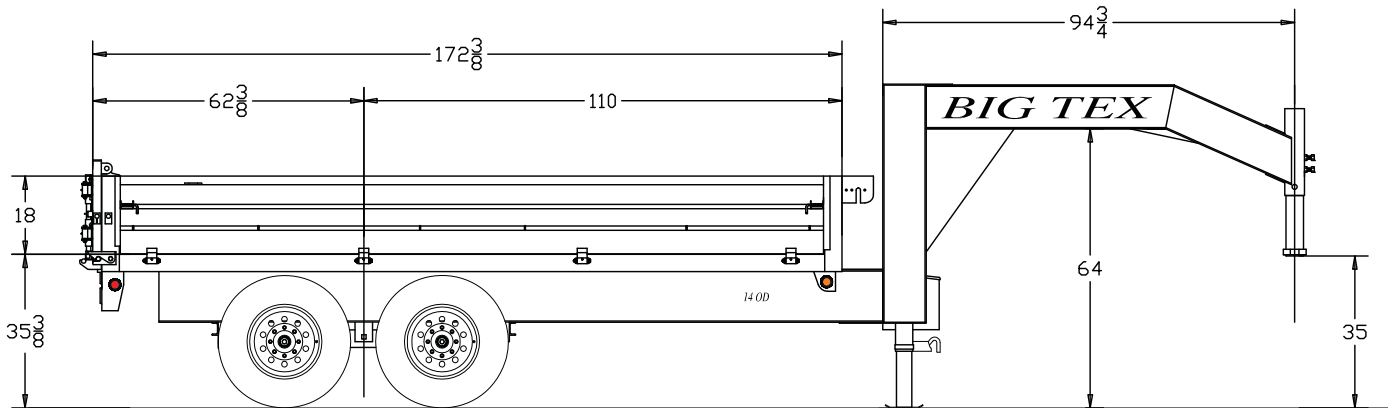

MODEL#	DESCRIPTION
14OD	96" x 14' Over the Axle Bumper Pull Dump
14OD-GN	96" x 14' Over the Axle Gooseneck Dump

TRAILER WEIGHTS & CAPACITIES

LENGTH	EMPTY WEIGHT	PAYLOAD	BOX CAPACITY
14OD-14'	4,140#	9,860#	6.2 Cubic Yards
14OD-GN-14'	5,150#	8,850#	6.2 Cubic Yards

OPTIONS

Spare Tire (ST235/80 D-16 LR-E)	2 Watt Solar Charger
Tire Upgrade (ST235/16 LR-G)	5 Watt Solar Charger
Spare Tire Upgrade (ST235/16 LR-G)	110V Charger
Wireless Remote	Crank Style Roll Tarp