

12LX Tandem Axle Low Profile Extra Wide Dump

G.V.W.R.	12,000#	AXLES	Two 6,000# EZ Lube w/Elec. Brakes
G.A.W.R. (Ea. Axle)	6,000#	SUSPENSION	Multi-Leaf Slipper Spring w/Equalizer
COUPLER	2-5/16" Adjustable Forged	TIRE	ST235/80 R-16 Load Range E
SAFETY CHAINS	1/4" Grd. 70 w/Safety Latch Hook (2 each)	WHEEL	16 x 6 White Spoke 8 Bolt
JACKS	7K TW Drop Leg (Bolted On)	FLOOR	10 Gauge Smooth Steel
TONGUE	6" Channel	LIGHTS	LED D.O.T. Stop, Tail, Turn & Clearance
FRAME	6" x 3" Rect Tube	ELEC. PLUG	7-Way RV
CROSSMEMBERS	6" Channel	FINISH (Prep)	Steel is Cleaned to Ensure a Professional Smooth Finish.
BED CROSSMEMBERS	3" Channel	FINISH	Superior Quality Finish is Applied for a Highly Decorative and Protective Finish.
BED LONG SILS	3" Channel		
BED SIDE RAILS	6-1/2" Formed Angle		
FENDERS	Double Square Broke Diamond Plate		

Standard Features

- Safety Chains Attached w/Cold Rolled Eyelets
- Lockable Pump & Battery Box Mounted in Front of Bed
- 24", 12 Ga. Sides w/Formed Channel Supports
- Modular Sealed Wiring Harness
- 10 Ga. Floor
- J-Hooks for Tie Down
- Stake Pockets
- Fully Formed Shroud for Tarp
- 4-5/8" D-Rings Inside Bed
- Self Contained Electric/Hydraulic Scissor Lift
- 45 Degree Dump Angle
- Cambered EZ Lube Axles w/Electric Brake on Each
- Complete Break-A-Way System w/Charge Line
- Grommet Mount Sealed LED Lighting
- Combo Gate

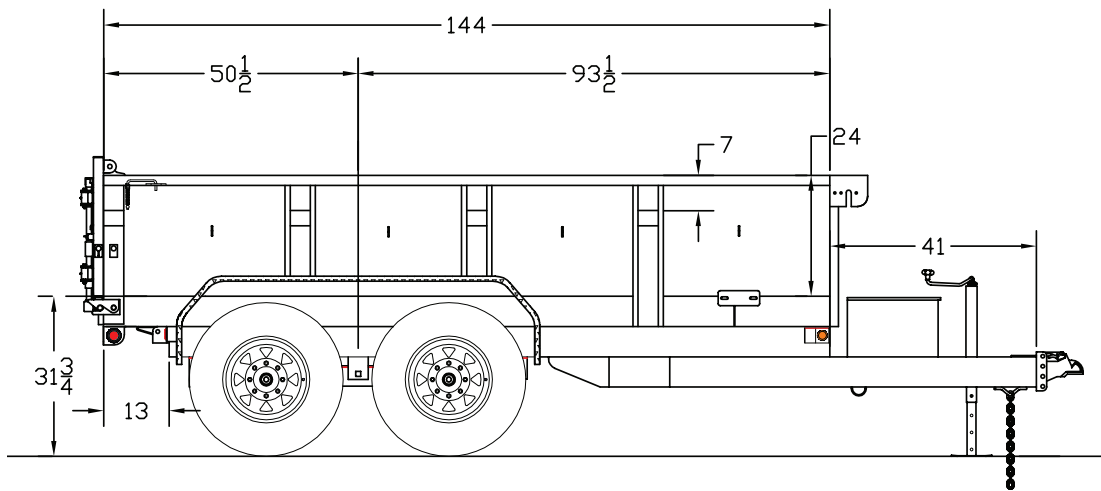

MODEL#	DESCRIPTION
12LX-12	83" x 12' Low Profile Tandem Axle Dump

TRAILER WEIGHTS & CAPACITIES

LENGTH	EMPTY WEIGHT	PAYLOAD	BOX CAPACITY
12'	3,820#	8,180#	6.2 Cubic Yards

OPTIONS

Adjustable Pintle in Channel	Wireless Remote
Hydraulic Surge Brakes on Both Axles	2 Watt Solar Charger
12K Heavy Duty Top Wind Drop Leg Jack	5 Watt Solar Charger
Spare Tire (ST235/80 R-16 LR-E)	110V Charger
24" Expanded Metal Side Extensions - 12'	Crank Style Roll Tarp
7' Slide In Ramps	