

10SR Tandem Axle Single Ram Dump

G.V.W.R.	9,990#	AXLES	Two 5,200# EZ Lube w/Elec. Brakes
G.A.W.R. (Ea. Axle)	5,200#	SUSPENSION	Multi-Leaf Spring w/Equalizer
COUPLER	2-5/16" Adjustable Forged	TIRE	ST235/80 D-16 Load Range E
SAFETY CHAINS	1/4" Grd. 70 w/Safety Latch Hook (2 each)	WHEEL	16 x 6 White Spoke 6 Bolt
JACKS	7K TW Drop Leg (Bolted On)	FLOOR	10 Gauge Smooth Steel
TONGUE	6" Channel	LIGHTS	LED D.O.T. Stop, Tail, Turn & Clearance
FRAME	6" Channel	ELEC. PLUG	7-Way RV
CROSSMEMBERS	8" Channel	FINISH (Prep)	Steel is Cleaned to Ensure a Professional Smooth Finish.
BED CROSSMEMBERS	2" x 2" Tubing	FINISH	Superior Quality Finish is Applied for a Highly Decorative and Protective Finish.
BED LONG SILS	4" Channel		
BED SIDE RAILS	6 1/2" Formed Angle		
FENDERS	9" x 72" Double Square Broke Diamond Plate		

Standard Features

- Safety Chains Attached w/Cold Rolled Eyelets
- Lockable Pump & Battery Box Mounted in Front of Bed
- Modular Sealed Wiring Harness
- 24", 12 Ga. Sides
- 10 Ga. Floor
- J-Hooks for Tie Down
- 13 Stake Pockets (Sides & Front)
- Fully Formed Shroud for Tarp
- Self Contained Electric/Hydraulic Single Cylinder Lift
- 45 Degree Dump Angle
- Cambered EZ Lube Axles w/Electric Brake on Each
- Complete Break-A-Way System w/Charge Line
- Grommet Mount Sealed LED Lighting
- Combo Gate
- Available in Black Only

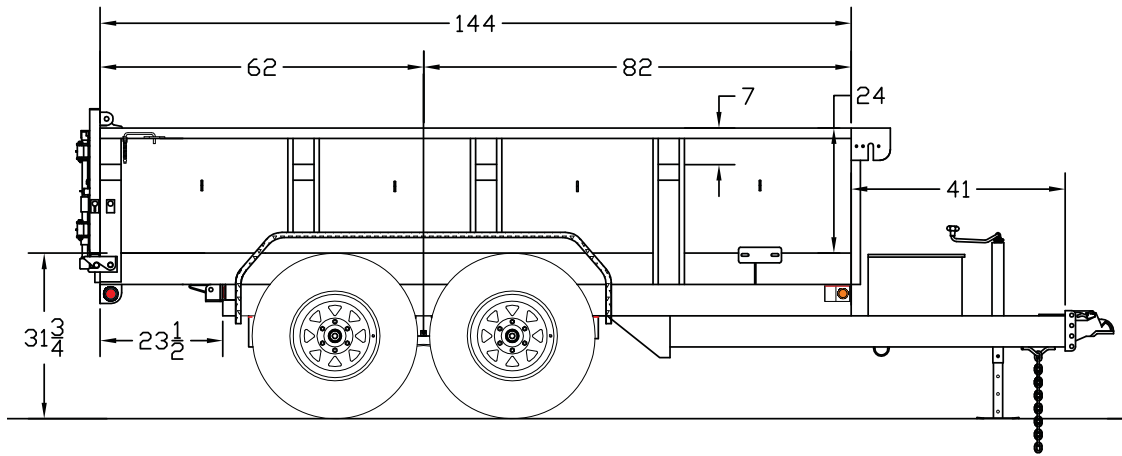

MODEL#	DESCRIPTION
10SR-12XL	83" x 12' Low Profile Tandem Axle Dump

TRAILER WEIGHTS & CAPACITIES

LENGTH	EMPTY WEIGHT	PAYLOAD	BOX CAPACITY
12'	3,730#	6,660#	6.1 Cubic Yards

OPTIONS

Spare Tire (ST 235/80 D-16 LR-E)	5 Watt Solar Charger
7' Slide In Ramps	110V Charger
Wireless Remote	Crank Style Roll Tarp
2 Watt Solar Charger	

STANDARD MODEL - NO OTHER OPTIONS AVAILABLE