

# 10ET

## Pro Series Tandem Axle Equipment

<b>G.V.W.R.</b>	9,990#	<b>AXLES</b>	Two 5,200# EZ Lube w/Electric Brakes
<b>G.A.W.R. (Ea. Axle)</b>	5,080#	<b>SUSPENSION</b>	Multi-Leaf Spring w/Equalizer
<b>COUPLER</b>	Adjustable Forged 2-5/16"	<b>TIRE</b>	ST225/75-15 Load Range D
<b>SAFETY CHAINS</b>	1/4" Grd. 70 w/Safety Latch Hook (2 each)	<b>WHEEL</b>	15 x 6 White Spoke 6 Bolt
<b>JACK</b>	7K Drop Leg (Bolted On)	<b>FLOOR</b>	2" Pine
<b>TONGUE</b>	5" Channel Fold Back	<b>LIGHTS</b>	D.O.T. Stop, Tail, Turn & Clearance
<b>TOP RAIL</b>	None	<b>ELEC. PLUG</b>	7-Way RV
<b>FRAME</b>	5" Channel	<b>FINISH (Prep)</b>	Steel is Cleaned to Ensure a Professional Smooth Finish.
<b>CROSSMEMBERS</b>	3" Channel	<b>FINISH</b>	Superior Quality Finish is Applied for a Highly Decorative and Protective Finish.
<b>UPRIGHTS</b>	None		
<b>FENDERS</b>	9" x 72" Tear Drop w/Back (Removable)		

### Standard Features

- Adjustable Forged Coupler
- Safety Chains Attached w/Cold Rolled Eyelets
- 7K Drop Leg Jack
- Lower Jack Support Plate
- Fold Back Tongue (14' and longer)
- Reflective Marker Tape
- Tie Down Pockets, Sides & Front
- 2" Tubular Stop Rail
- Floor Secured w/Torx Screws
- Cambered EZ Lube Axles w/Electric Brake on Each
- Complete Break-A-Way System w/Charger
- Spare Tire Mount
- 32" Dovetail
- 5' Stand-Up Ramps w/Support Leg
- Grommet Mount Sealed Lighting

Dimensions			
Length	A	B	C
16'	193-1/2"	115"	78-1/2"
18'	217-1/2"	127"	90-1/2"
20'	240"	138"	102"

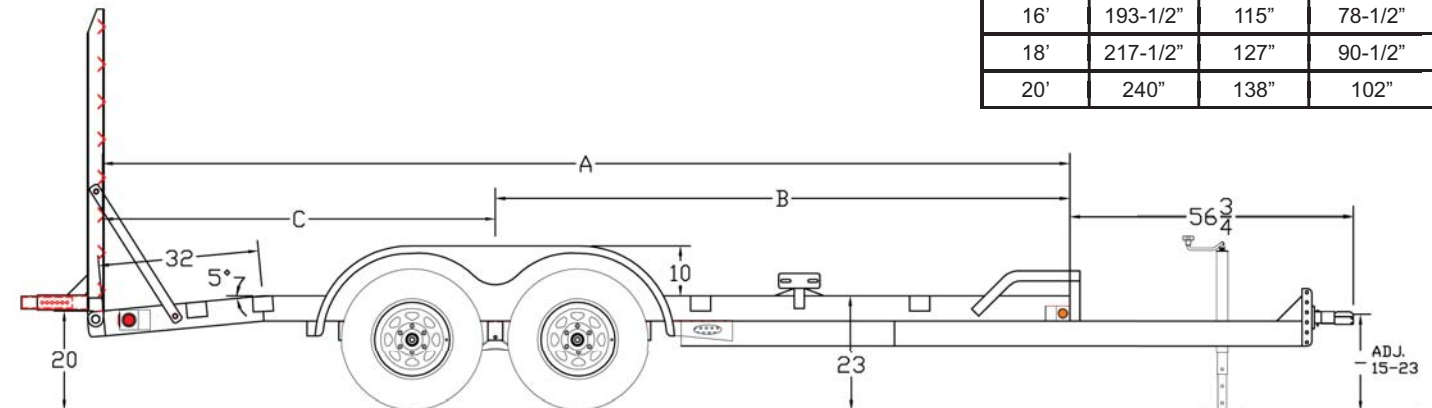

MODEL#	WEIGHT	DESCRIPTION
10ET-16	2,300#	83" x 16' Tandem Axle Equipment Trailer
10ET-18	2,460#	83" x 18' Tandem Axle Equipment Trailer
10ET-20	2,660#	83" x 20' Tandem Axle Equipment Trailer

### OPTIONS

12K Drop Leg Jack - Top Wind	Spare Tire (ST225/75-15 LR-D)
12K Drop Leg Jack - Side Wind Against Bed	Tire Upgrade (ST235 D-16 LR-E)
Hydraulic Surge Brakes 2 Axles	Spare Tire Upgrade (ST235 D-16 LR-E)
Gooseneck in Lieu of Bumper Pull	LED Lighting