

# 10LX Tandem Axle Low Profile Extra Wide Dump

<b>G.V.W.R.</b>	9,990#	<b>AXLES</b>	Two 5,200# EZ Lube w/Elec. Brakes
<b>G.A.W.R. (Ea. Axle)</b>	5,200#	<b>SUSPENSION</b>	Multi-Leaf Spring w/Equalizer
<b>COUPLER</b>	2-5/16" Adjustable Forged	<b>TIRE</b>	ST235/80 D-16 Load Range E
<b>SAFETY CHAINS</b>	1/4" Grd. 70 w/Safety Latch Hook (2 each)	<b>WHEEL</b>	16 x 6 White Spoke 6 Bolt
<b>JACKS</b>	7K TW Drop Leg (Bolted On)	<b>FLOOR</b>	10 Gauge Smooth Steel
<b>TONGUE</b>	6" Channel	<b>LIGHTS</b>	LED D.O.T. Stop, Tail, Turn & Clearance
<b>FRAME</b>	6" Channel	<b>ELEC. PLUG</b>	7-Way RV
<b>CROSSMEMBERS</b>	4" 13# I-Beam	<b>FINISH (Prep)</b>	Steel is Cleaned to Ensure a Professional Smooth Finish.
<b>BED CROSSMEMBERS</b>	3" Channel	<b>FINISH</b>	Superior Quality Finish is Applied for a Highly Decorative and Protective Finish.
<b>BED LONG SILS</b>	3" Channel		
<b>BED SIDE RAILS</b>	6-1/2" Formed Angle		
<b>FENDERS</b>	Double Square Broke Diamond Plate		

## Standard Features

- Safety Chains Attached w/Cold Rolled Eyelets
- Lockable Pump & Battery Box Mounted in Front of Bed
- 24", 12 Ga. Sides w/Formed Channel Supports
- Modular Sealed Wiring Harness
- 10 Ga. Floor
- J-Hooks for Tie Down
- Stake Pockets
- Fully Formed Shroud for Tarp
- 4-5/8" D-Rings Inside Bed
- Self Contained Electric/Hydraulic Scissor Lift
- 45 Degree Dump Angle
- Cambered EZ Lube Axles w/Electric Brake on Each
- Complete Break-A-Way System w/Charge Line
- Grommet Mount Sealed LED Lighting
- Combo Gate

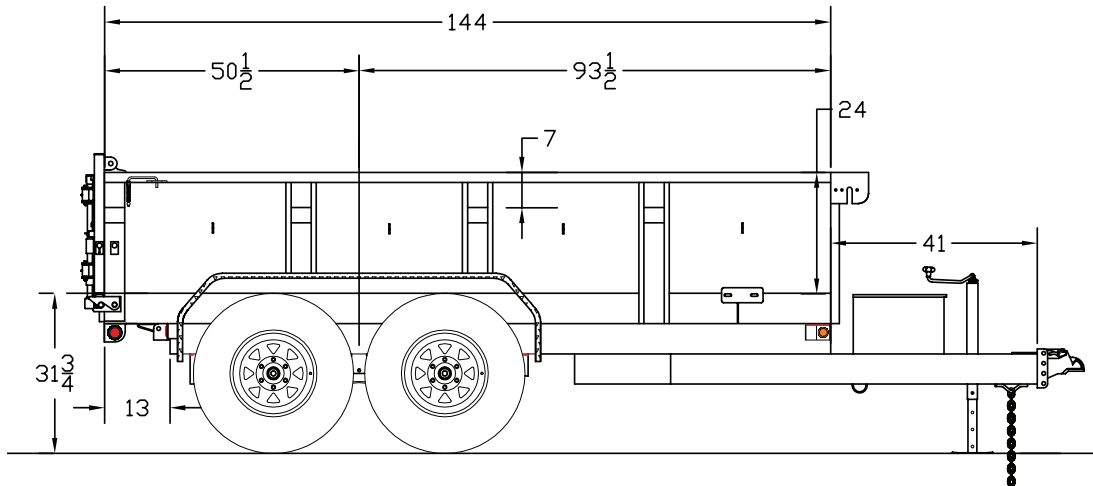

MODEL#	DESCRIPTION
10LX-10	83" x 10' Low Profile Tandem Axle Dump
10LX-12	83" x 12' Low Profile Tandem Axle Dump

## TRAILER WEIGHTS & CAPACITIES

LENGTH	EMPTY WEIGHT	PAYLOAD	BOX CAPACITY
10'			5.2 Cubic Yards
12'	3,570#	6,430#	6.2 Cubic Yards

### OPTIONS

Adjustable Pintle in Channel	7' Slide In Ramps
Hydraulic Surge Brakes on Both Axles	Wireless Remote
12K Heavy Duty Top Wind Drop Leg Jack	2 Watt Solar Charger
Spare Tire (ST235/80 D-16 LR-E)	5 Watt Solar Charger
24" Expanded Metal Side Extensions - 10'	110V Charger
24" Expanded Metal Side Extensions - 12'	Crank Style Roll Tarp